

Real Time Automated Fabric Defect Detection System using Microcontroller

Tamnun E Mursalin^{*1}, Fajrana Zebin Eishita^{*2}, Ahmed Ridwanul Islam^{*3},
Dr. Md Jahangir Alam^{*4}

**1 Corresponding author Associate Professor, University Of Liberal Arts-Bangladesh, CSE
PhD Student, Institute Of Business Administration, Dhaka University*

**2 Lecturer, American International University-Bangladesh (AIUB), CS, Banani, Dhaka,
M.Sc. Student, Department of Computer Science,
American International University, Bangladesh*

**3 Software Engineer, M.Sc. Student, Department of Computer Science, American International
University-Bangladesh (AIUB)*

**4 Associate Professor, Institute Of Business Administration (IBA), Dhaka University,
tamnun.mursalin@ulab.edu.bd, eishita@aiub.edu, aridwan@gmail.com, jalam@iba-du.edu*

Abstract

In a Least Developed Country (LDC) like Bangladesh where the textile is the main core of our economy; still there is a major drawback in this sector which is the defect detection of the fabric. In the manual fault detection system with highly trained inspectors, very less percentage of the defects are being detected in upon fabrics in the textile industries. But a real time automatic system can increase this percentage in a maximum number. This research implements a textile defect detector which uses computer vision methodology with the combination of multi-layer neural networks to identify the classification of textile defects and detect it with a real time configured mechanical system containing a microcontroller. The recognizer, suitable for LDC countries, specially for Bangladesh where textile exports earns the maximum for the country's economy.

Keywords

Real time, neural networks, LDC, QIS, PICProg, PICmicro emulator, Then PicBasic Pro 2.45, perceptron network, fuzzified.

1. Introduction:

Now a day textile business in one of the major business all over the world. For example, developing countries like Bangladesh where textile industry that includes knitwear and ready-made garments along with specialized textile products, is the nation's number one export earner. The sector, which employs 2.2 million workers, accounted for 75 per cent of Bangladesh's total exports of US\$10.53 billion in FY2005-06, in the process logging a record growth rate of 24.44 per cent. [1] But one of the greatest weaknesses in this field is the loss of fabric due to defects on those. We can reduce the loss from this field up to the maximum using our "Automated fabric fault Detection Mechanism using microcontroller".

In the least developed countries like Bangladesh, most defects arising in the production process of a textile material are still detected by human inspection. The work of inspectors is very tedious and time consuming. They have to detect small details that can be located in a wide area that is moving through their visual field. The identification rate is about 70%. In addition, the effectiveness of visual inspection decreases quickly with fatigue. Digital image processing techniques have been increasingly applied to textured samples analysis over the last ten years [2]. Wastage reduction through accurate and early stage detection of defects in fabrics is also an important aspect of quality improvement. Table 1 [3] summarizes the comparison between human visual inspection and

Table 1. Visual inspection versus automated inspection

Inspection Type	Visual	Automate d
Fabric Types	100%	70%
Defect Detection	70%	80%+
Reproducibility	50%	90%+
Objective Defect Judgment	50%	100%
Statistics Ability	0%	95%+
Inspection Speed	30 m/min	120 m/min
Response Type	50%	80%
Information Content	50%	90%+
Information Exchange	20%	90%+

automated inspection. Also, it has been observed [4] that price of textile fabric is reduced by 45% to 65% due to defects.

All textile industries aim to produce competitive fabrics. The competition enhancement depends mainly on productivity and quality of fabrics. In textile sector, there have a enlarge amount of loss occurred by faulty fabrics. Everyday minimum 2000 square feet fabrics are wasted only for fault where maximum amount of fabric may not faulty [4]. There are different types of faults available in Textile i.e. hole, scratch, stretch, fly, yarn, dirty spot, slub, cracked point, color bleeding etc; if not detected properly these faults can affect the production process massively.

Machine vision automated inspection system for textile defects has been in the research industry for longtime [5], [6]. Recognition of patterns independent of position, size, brightness and orientation in the visual field has been the goal of much recent work. However, there is still a lack of work in machine vision automated system for recognizing textile defects using AI. A neural network pattern recognizer was developed in [7]. Fully connected three multilayer perceptron network was used to identify different sizable objects. The input of this network is seven standardized invariant moment and the weights are trained using back propagation. Since the network uses standardized moments as input, neural net similar to this requires lots of iteration to train. The research takes directly input as binary images as a result no preprocessing of image is performed. Today's automated fabric inspection systems are based on adaptive neural networks. So instead of going through complex programming routines, the users are able to simply

scan a short length of good quality fabric to show the inspection system what to expect. This coupled with specialized computer processors that have the computing power of several hundred Pentium chips makes these systems viable [8]. Three state-of-the-art fabric inspection systems are – BarcoVision's Cyclops, Elbit Vision System's I-Text and Zellweger Uster's Fabriscan. These systems can be criticized on grounds that they all work under structured environments – a feat that is almost non-existent in list developed countries like Bangladesh.

There are some works in [9] based on the optical Fourier transform directly obtained from the fabric with optical devices and a laser beam. Digital image processing techniques have been increasingly applied to textured samples analysis over the last ten years. Several authors have considered defect detection on textile materials. Kang et al. [10], [11] analyzed fabric samples from the images obtained from transmission and reflection of light to determine its interlacing pattern. Waveletshad been applied to fabric analysis by Jasper et al. [12], [13]. Escofet et al. [14], [15] have applied Gabor filters (wavelets) to the automatic segmentation of defects on non-solid fabric images for a wide variety of interlacing patterns. Millán and Escofet [16] introduced Fourier-domain-based angular correlation as a method to recognize similar periodic patterns, even though the defective fabric sample image appeared rotated and scaled. Recognition was achieved when the maximum correlation value of the scaled and rotated power spectra was similar to the autocorrelation of the power spectrum of the pattern fabric sample.

A novel idea for fault detection and identification of woven textile structures were introduced and implemented by J.Lewis Dorrity, Georgia Institute of Technology, G. Vachtsevanos, Georgia Institute of Technology, Warren Jasper, North Carolina State University [17].A survey of major textile defects was conducted as well as the associated tangible and intangible costs was identified. Fractal scanning was developed to scan the digitized image of textile fabrics. A fuzzified wavelet transform algorithm with adaptive noise rejection and on-line learning is used to extract features and a knowledge based inference engine is called upon to declare the defect categories. Off-line learning is introduced to maximize the detectability and identifiability measures. The viability of this technique is shown by test results of major textile fabric defects. From the literature it is clear that there exists many systems that can detect textile defects but hardly affordable by the small industries of the List Developed countries like Bangladesh.

In this paper we propose an automatic textile defect recognizer as a first step for a future complete industrial Quality Information System (QIS) in textile industries of Bangladesh. This scheme can detect three types of very common faults in textile production, that are hole, scratch and fade. An automated textile defect detector based on computer vision methodology and adaptive neural networks is built combining engines of image processing and artificial neural networks with a microcontroller in textile industries research arena. Here the textile defect recognizer is viewed as a real-time control agent that transforms the captured digital image into adjusted resultant output and operates the automated machine through the microcontroller, In the proposed system as the recognizer identifies a fault of any type mentioned above, will immediately recognize the type of fault which in return will trigger the laser beams in order to display the upper offset and the lower offset of the faulty portion. The upper offset and the lower offset implies the 2 inches left and 2 inches right offset of faulty portion. This guided triggered area by the laser beams will indicate the faulty portion that needs to be extracted from the roll. For this the automated system generates a signal to

stop the rotation of the stepper motor and cut off the faulty portion. Whenever the signal is generated the controller circuit stops the movement of the carrying belt and the defective portion of the fabric is removed from the roll. Then after eliminating the defective part again a signal is generated to start the stepper motor and continue the further process. Here the whole system implementation is done in a very simple way. In addition to this the hardware equipments are so cheap that a LDC like Bangladesh can easily effort it and can make the best use of the scheme.

2. Overview and Mythology

Major steps required to implement the proposed system is depicted in Figure 1 and Figure 2. The proposed system can be a competitive model for recognizing textile defects in real world. Base on the research, the proposed system design is separated into two parts. The first part of the research focuses on the on the processing of the images to detect the faults and the second part is removing the defect part from the fabric.

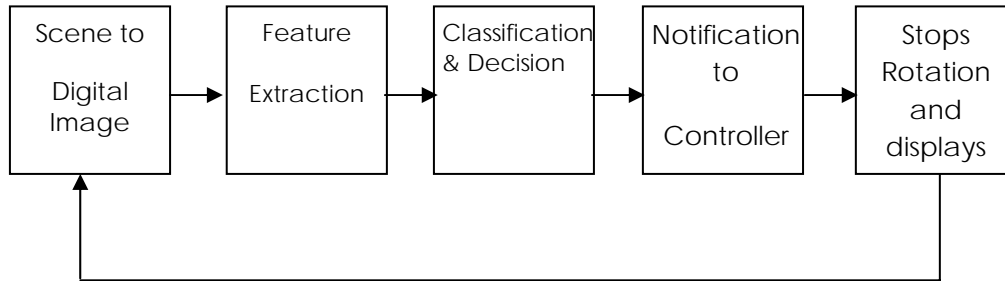

Figure 1. Image Inspection Chain

The first part of the system which is basically the software part of the system can be classified in two parts again. The first part focuses on the processing of the images to prepare to feed into neural network. The second part is about building a neural network that best performs on the criteria to sort out the textile defects. This whole soft component is implemented using MATLAB.

The second part of the scheme is the hardware section. The whole hardware system is controlled by a microcontroller circuit. Whenever the software detects a fault in the fabric it sends a signal to the microcontroller and it stops the system for a while to eliminate the defective part of the fabric. The working procedure of the whole system can be observed from figure-1 and figure-2.

3. Implementation

As it is mentioned in the mythology that the whole system consist of two major parts – software and the microcontroller so the implementation is also made by the two consequent parts.

3.1 Software Implementation

3.1.1 Processing Textile Image for the Neural Network Input

At first the images of the fabric is captured by digital camera in RGB format (top left image in figure and

figure) and passes the image through serial port to the computer. Then, noise is removed using standard

techniques and an adaptive median filter algorithm has been used as spatial filtering for minimizing time

complexity and maximizing performance [18] to converts digital (RGB) images to grayscale images

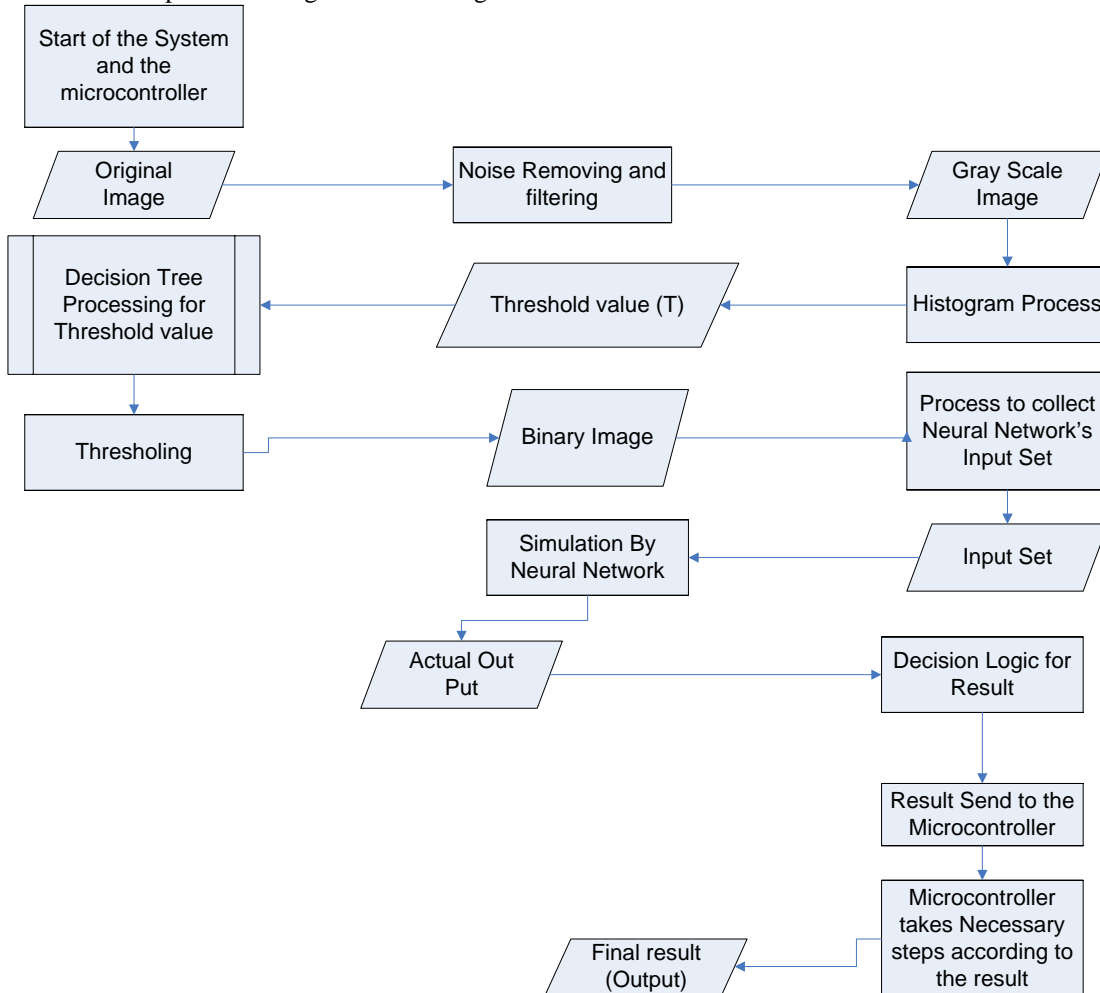

Figure 2. Major components of the textile defect detector

(top middle image in Fig. 3). After restoration local thresholding technique (the process is discussed in next sub-section) is used in order to convert grayscale image into binary image (top right in Fig. 3). Finally, this binary image is used to calculate the following attributes:

1. **The area of the faulty portion:** calculates the total defected area of a image.

2. **Number of objects:** uses image segmentation to calculate the number of labels in an image.

3. **Shape factor:** distinguishes a circular image form a noncircular image. Shape Factor uses the area of a circle to identify the circular portions of the fault.

These three attributes are used as input sets to adapt the neural net through training set in order to recognize expected defects.

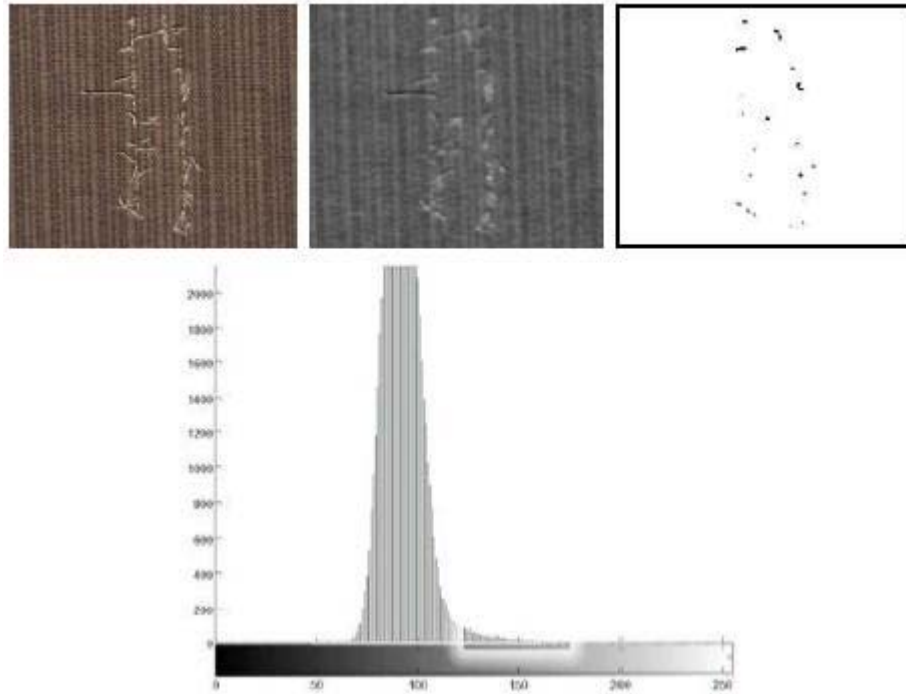

Figure 3. Original Faulty (Scratch) Fabric (top left), gray (top middle) and binary (top right) representation and histogram (bottom) of the gray

A decision tree is constructed based on the histogram of the image in hand to convert the gray scale image in a binary representation. As we know from the problem description that there are different types of textile fabrics and also different types of defects in textile industries hence different threshold values to different pattern of faults there is no way to generalize threshold value (T) from one image for all

types of fabrics. Notice this phenomenon in histograms illustrated in Fig. 3. (The identified threshold value (T) should be greater than 120 and less than 170) and Fig. 4. (The identified threshold value (T) should be greater than 155 and less than 200). A local threshold was used based on decision tree which was constructed using set of 200 image histograms of fabric data.

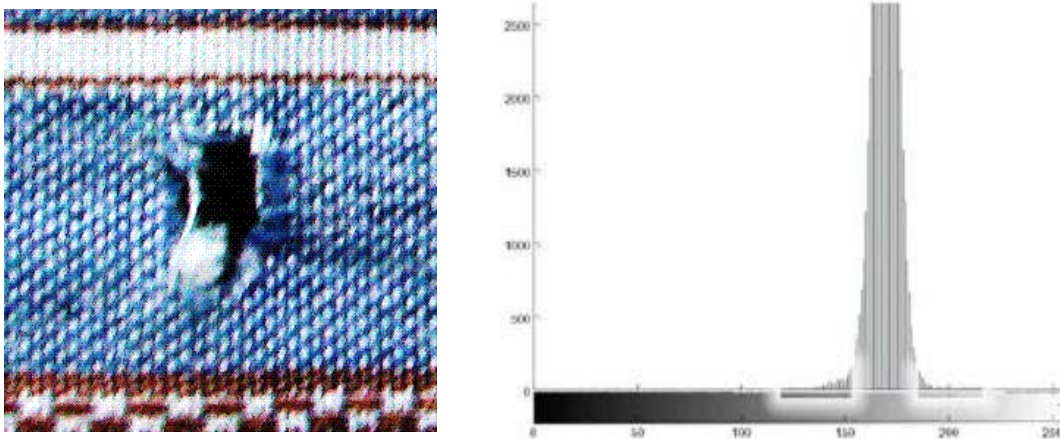

Figure 4. Original Faulty (Hole) Fabric (left) and the histogram of the gray representation (right)

3.1.2 The Neural Network

In search of a fully connected multi-layer neural network that will sort out the defected textiles we start with a two layer neural network (Fig. 6). Our neural network contains one hidden of 44 neurons and one output layer of 4 neurons. The neurons in the output layer is delegated as 1st neuron of the output layer is to Hole type fault, 2nd neuron of the output layer is to Scratch type fault, 3rd neuron of the output layer is to

fade and 4th neuron of the output layer is for No fault (not defected fabric). The output range of the each neuron is in the range of [0 ~ 1] as we use log-sigmoid threshold function to calculate the final out put of the neurons. Although during the training we try to reach the following for the target output $\{[1\ 0\ 0\ 0], \{0\ 1\ 0\ 0\}, \{0\ 0\ 1\ 0\}, \{0\ 0\ 0\ 1\}\}$ consecutively for Hole type defects, Scratch type defects, Other type defects and No defects, the final output from the output layer is determined using the winner- take-all method.

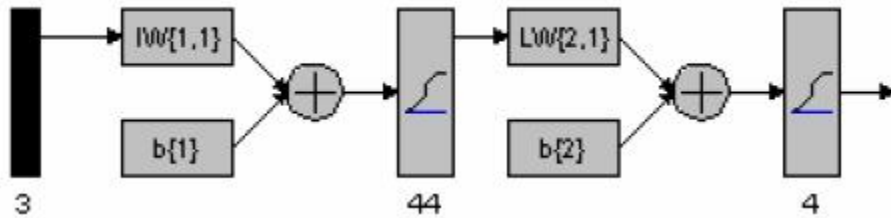

Figure 6. Design of Feed Forward Back propagation Neural Network

3.2 Microcontroller Implementation

In order to program the microcontroller PICProg is used to burn the program into the PIC16F84A. It is pic basic program which uses the serial port of the computer and a simple circuit. The code for the PIC was written and saves as *.asm file. Then PicBasic Pro 2.45 was used to convert it into an *.hex file and after that using PICProg the hex file was written into the PIC. The outlet of the microcontroller is exposed in figure 7 and figure 8.

The circuit main contains three parts:

1. **Implementation of 12-Volt DC power supply:**
 To implement this circuit, it needs two diode, one transformer or (24 v peak to peak) one

capacitor of 470 μ F and one resistor. Here the centre tap rectifier converts the AC into DC. One capacitor is used in parallel to the load to stable the output at a fixed voltage. After that a 470 μ F is connected to the circuit to get fixed 12 volt as the rectifier was giving not adjusts 12 volt.

2. **Arrangement of Microcontroller:** 12V DC applied to stepper motor voltage terminal and as an input of a Voltage Regulator 7805 which provides 5V DC. After burnt the Microcontroller these 5V supplied to the Vdd and MCLR and Vss connected with ground. OSC1 is connected with 5V DC through 4.7K resistances. Port A0,A1,A2 is used in a switch to control Stepper motor speed and direction.

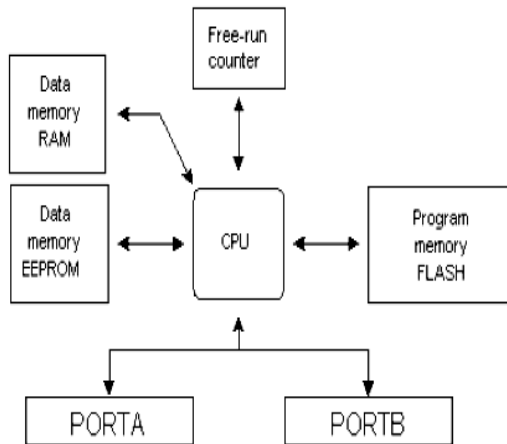

Figure 7. PIC 16F84A Microcontroller Outline

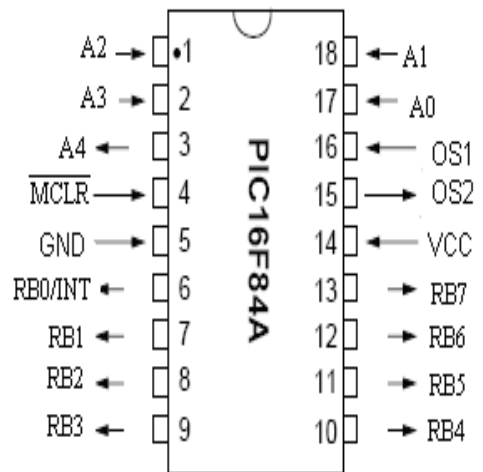

Figure 8. PIC16F84A

3. **Implementation of switching circuit to control a stepper motor:** Here four Transistors have been used (BD135), which Bases (B) is connected to the Microcontroller port B0, B1, B2 and B3 through 1K resistances. Transistor's Emitters (E) are shorted and connected with

ground. Collectors (C) are connected to the motor windings in sequentially. The pulse width is passing from port B0, B1, B2 and B3 to the stepper motor windings according to the code.

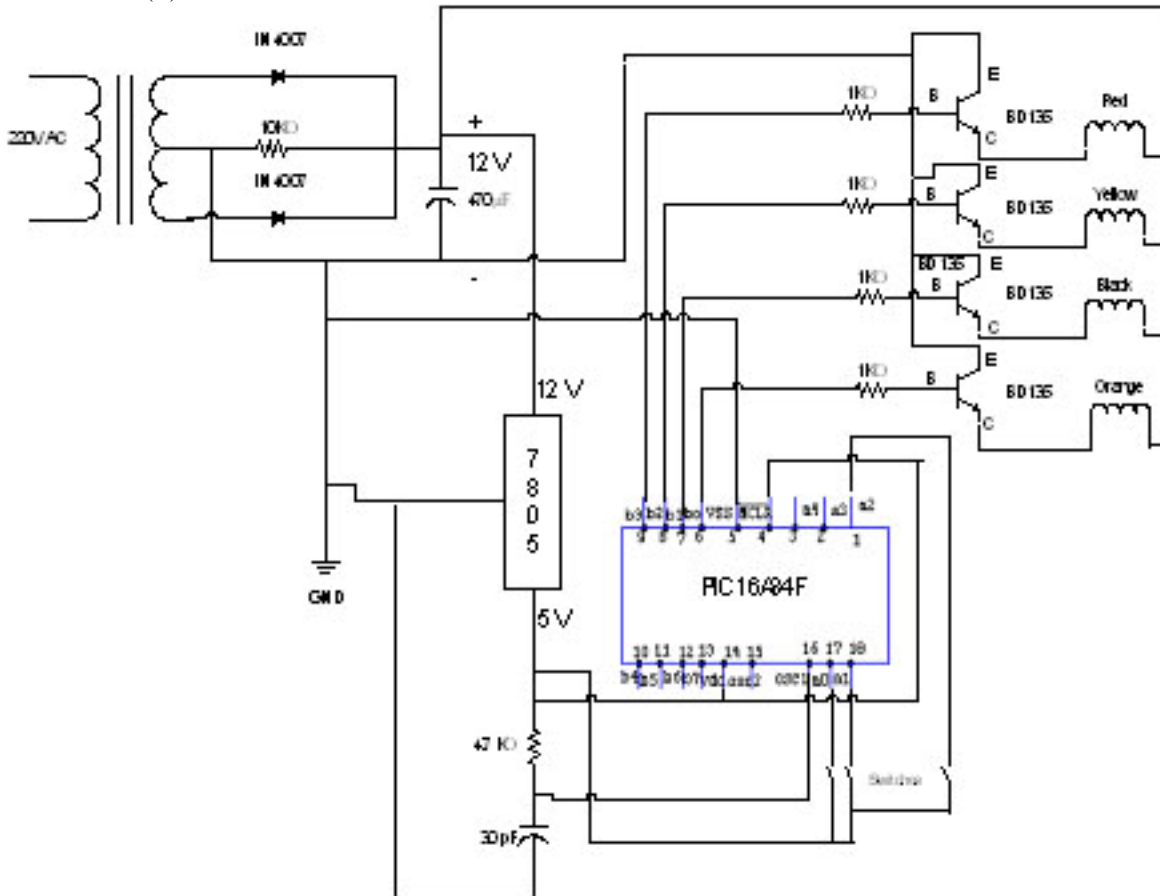

Figure 9. Complete Circuit Diagram

As depicted on Figure 9, the circuit consists of four TIP122 power transistors (T1, T2,T3 & T4), 330ohm resistors (R1, R2,R3 & R4), 3.3k ohm(R5,R6,R7 & R8), IN4007 freewheeling diodes (D1,D2,D3 & D4) and one inverter IC 7407 which is used as buffer chip (IC1). The 7407 buffer used here is a hex-type open-collector high-voltage buffer. The 3.3k ohm resistors are the pull up resistors for the open-collector buffer. The input for this buffer comes from the parallel port. The output of the buffer is of higher current capacity than the parallel port output, which is necessary for triggering the transistor; it also isolates the circuit from the PC parallel port and hence provides extra protection against potentially dangerous feedback voltages that may occur if the circuit fails. The diode connected across the power supply and the collector is used as a

freewheeling diode and also to protect the transistor from the back EMF of the motor inductance. The motor used in this project was two STM 901 from Srijan Control Drives. The common of four parallel port is connected with the power supply (VCC) of 5V and head of four parallel is connected to the respective of printer port pin no 2, 3, 4 & 5 and pin no 25 is connected with common point of ground of the circuits.

During normal operation, the output pattern from the PC drives the buffer, and corresponding transistors are switched on. This leads to the conduction of current through these coils of the stepper motor which are connected to the energized transistor. This makes the motor move one step forward. The next pulse will trigger a new combination of transistors, and hence a new set of

coils, leading to the motor moving another step. The scheme of excitation that we have used here has already been shown above.

In this construction, 50V- 470mf capacitor is used for filtering or discharging voltage while converting to pure DC from AC power supply. Regulator IC 7812 is used for voltage transferring down from 24V to 5V. Then a positive voltage (+ve) is supplied from the board to one of the motors (red) and the other wire point is used for grounding (maroon).

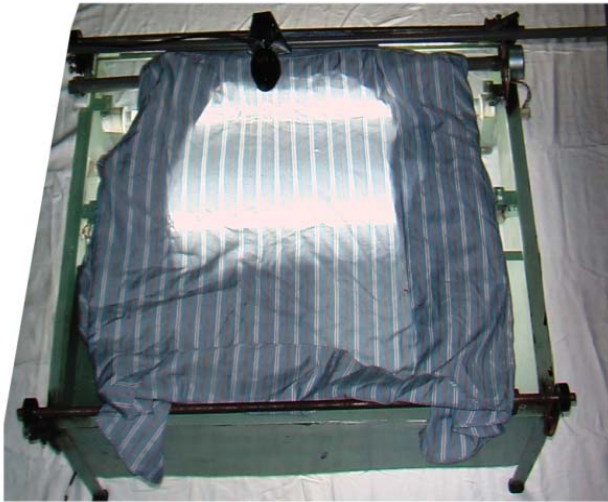

Figure 10. The real system

LED is used for examining the proper voltage supply to the circuit. Capacitor is used for discharging so that no charge is hold. Regulator IC 7805 is used for transferring down voltage from 12V to 5V. Resistance of 330ohm, 10k ohm is used to guard the LED from impairment. For getting pure DC voltage from supplied AC voltage, diode IN 4007 is used. From this circuit, a positive voltage is supplied to the other motor of our experiment just like the other transformer board and the point is grounded.

The real mechanism and the detection process of faulty part are shown in figure-10 and figure-11 respectively.

4. Result and Discussion

The detection of fault in the system is basically done by thresholding through the Neural Network. The overall average output of the system is exposed in the chart of figure-10. Here it is shown that the recognizer can successfully identifying hole is 86%, fade is 66%, scratch 77% . The overall average accuracy to detect fault is 76.3%.

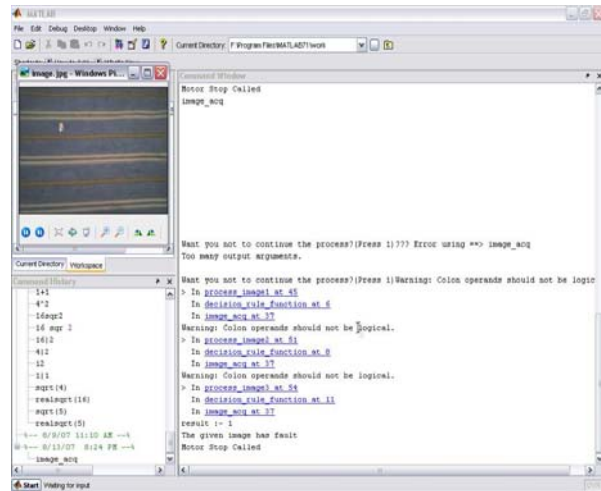

Figure 11. Fault: Hole, Output: The Given Image

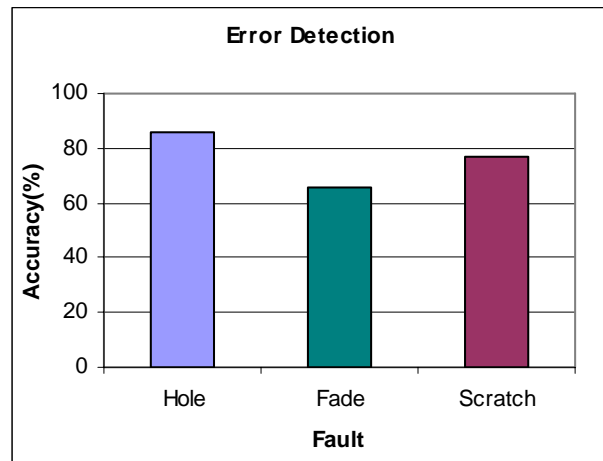

Figure 12. The bar chart for the performance

5. Conclusion

In most of the textile garment factories of Bangladesh the defects of the fabrics are detected manually. The manual textile quality control usually goes over the human eye inspection. Notoriously, human visual inspection is tedious, tiring and fatiguing task, involving observation, attention and experience to detect correctly the fault occurrence. The accuracy of human visual inspection declines with dull jobs and endless routines. Sometimes slow, expensive and erratic inspection is the result. Therefore, the automatic visual inspection protects both: the man and the quality. Here, it has been demonstrated that Textile Defect Recognition System is capable of detecting fabrics' defects with more accuracy and efficiency. In the research arena, our system tried to use the local threshold technique without the decision tree process. Since our recognizer deals with different types of faults

and fabrics, therefore the recognition system cannot access a general approach for local thresholding technique.

The system works very well except the quality of the web camera. Because of which sometimes the perfect fabric is also found as faulty part. But this problem will be easily defeated if a good quality camera is used.

6. References

[1] http://en.wikipedia.org/wiki/Economy_of_Bangladesh#Textile_sector

[2] M. Ralló, M. S. Millán, J. Escofet, "Wavelet based techniques for textile inspection", *Opt. Eng.* 26(2), 838-844 (2003)

[3] R. Meier, "Uster Fabriscan, The Intelligent Fabric Inspection," [Online document], cited 20 Apr. 2005, Available [HTTP: http://www.kotonline.com/english_pages/ana_basliklar/uster.asp](http://www.kotonline.com/english_pages/ana_basliklar/uster.asp)

[4] Ahmed Ridwanul Islam, Farjana Zebin Eishita, Jesmine Ara Bubly, "Implementation of a Real Time Automated Fabric Defect Detection System" 2007.

[5] B. G. Batchelor and P. F. Whelan, "Selected Papers on Industrial Machine Vision Systems," SPIE Milestone Series, 1994

[6] T. S. Newman and A. K. Jain, "A Survey of Automated Visual Inspection," *Computer Vision and Image Understanding*, vol. 61, 1995, pp. 231–262.

[7] H Zhang, J. Guan and G. C. Sun, "Artificial Neural Network-Based Image Pattern Recognition", ACM 30th Annual Southeast Conference, 1992.

[8] A. Dockery, "Automatic Fabric Inspection: Assessing the Current State of the Art," [Online document], 2001, [cited 29 Apr. 2005]

[9] Ciamberlini C., Francini F., Longobardi G., Sansoni P., Tiribilli, B. "Defect detection in textured materials by optical filtering with structured detectors and selfadaptable masks", *Opt. Eng.* 35(3), 838-844 (1996)

[10] Kang T.J. et al. "Automatic Recognition of Fabric Weave Patterns by Digital Image Analysis", *Textile Res. J.* 69(2), 77-83 (1999)

[11] Kang T.J. et al. "Automatic Structure Analysis and Objective Evaluation of Woven Fabric Using Image Analysis", *Textile Res. J.* 71(3), 261-270 (2001)

[12] Jasper W.J., Garnier S.J., Potlapalli H., "Texture characterization and defect detection using adaptive wavelets", *Opt. Eng.* 35(11), 3140-3149 (1996)

[13] Jasper W.J., Potlapalli H., "Image analysis of mispicks in woven fabric", *Text. Res.J.* 65(1), 683-692 (1995)

[14] Escofet J., Navarro R., Millán M.S., Pladellorens J., "Detection of local defects in textile webs using Gabor filters", in "Vision Systems: New Image Processing Techniques" Ph. Réfrégier, ed. Proceedings SPIE vol. 2785, 163-170 (1996).

[15] Escofet J., Navarro R., Millán M.S., Pladellorens J., "Detection of local defects in textile webs using Gabor filters", *Opt. Eng.* 37(8) 2297-2307 (1998)

[16] Millán M.S., Escofet J., "Fourier domain based angular correlation for quasiperiodic pattern recognition. Applications to web inspection", *Appl. Opt.* 35(31), 6253-6260 (1996)

[17] J.Lewis Dorrity, G. Vachtsevanos, Warren Jasper, "REAL-TIME FABRIC DEFECT DETECTION AND CONTROL IN WEAVING PROCESSES", National Textile Center Annual Report: August 1995, Project No.G94-2

[18] R. C. Gonzalez, R. E. Woods, S. L. Eddins, "Digital Image Processing using MATLAB", ISBN 81-297-0515-X, 2005, pp. 76-104, 142-166, 404-